

# MOEN®

# Specifications

## DESCRIPTION

- Smart home water monitoring and leak detection system

## OPERATION

- Remote, automatic, and manual water on/off (shut-off) capability
- WiFi enabled device for smartphone connectivity
- Smartphone app available for iOS and Android that provides the following:
  - Proactive maintenance alerts (i.e. leak alert, pressure alerts, etc.)
  - Remote water control and shut-off
  - Set water consumption goals and monitor water usage
  - Set system modes (home, away, sleep)
  - See real-time flow, pressure, and temperature readings
  - Run manual leak detection tests "Health Tests"
- Works with Amazon Alexa, Google Assistant, IFTTT and Control4

## FLOW

- Maximum operating pressure of 175 psi

## STANDARDS

- Third party certified to standard IAPMO IGC 349 and all applicable standards listed therein
- Third party certified to standards UL1951, CSA C22.2 no. 14 and no. 68 and all applicable standards listed therein
- Third party certified to standards NSF 61/9 and NSF 372 and all applicable standards listed therein
- Conformant to FCC part 15 Class C
- Conformant to Innovation, Science and Economic Development Canada (ISED) RSS-247

## Installation Notes:

- Install product following the installation guide
- Must be installed on accessible main water supply line (cold water line) that is 0.75 inch diameter (can be installed on 1.25 inch diameter or smaller)
- Must be installed after water meter, water shut-off, and pressure regulating valve (if applicable)
- Power supply and device must not be installed where the ambient temperature can exceed 60 deg C or below 0 deg C
- Requires electrical outlet (100-240VAC-50/60 Hz) with continuous power within 6 feet of device
- Requires WiFi network (WLAN connectivity/IEEE 802.11 bgn, 2.4 GHz range)
- Smartphone (iPhone or Android) with installed app required

## For Well Pump System Installations:

- When installed on well or irrigation water service lines, the device should be placed after (downstream) of all treatment and filtration components to avoid debris interference. It should also be installed after the well pump and water storage tank. If it is necessary to install the device prior to a water filtration system, a wye strainer with a 100 mesh or finer screen and blow-down port is required to catch any sediment or particles from the ground source or casing. The mesh screen in the strainer may require periodic maintenance.



## Flo by Moen™ Smart Home Water Monitoring and Leak Detection System

Model: 900-001

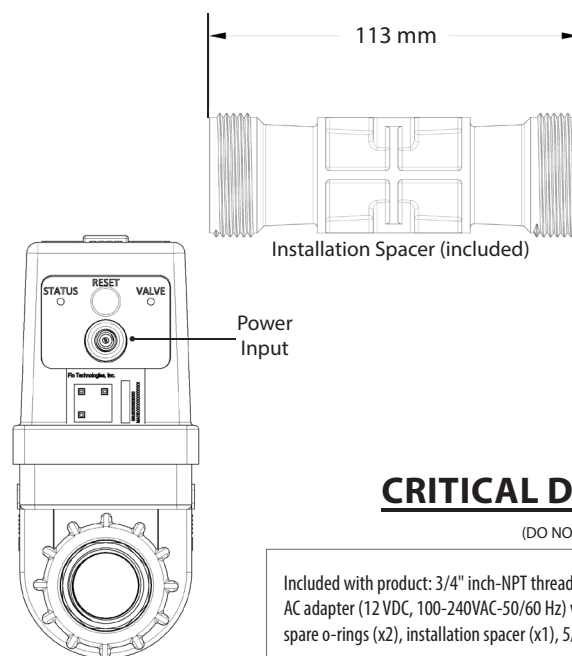
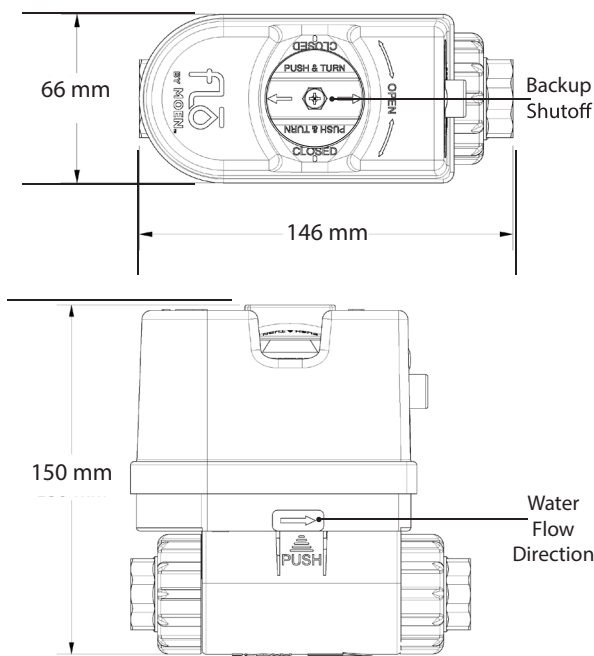
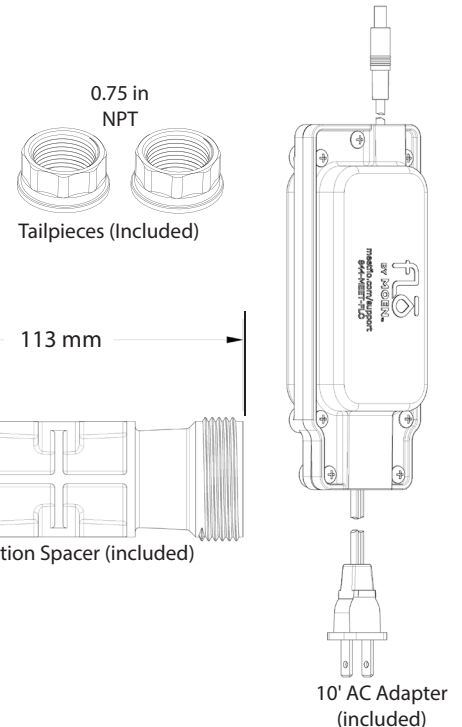

## CRITICAL DIMENSIONS

(DO NOT SCALE)

Included with product: 3/4" inch-NPT threaded brass tailpieces (x2), AC adapter (12 VDC, 100-240VAC-50/60 Hz) with 10' cable (x1), spare o-rings (x2), installation spacer (x1), 5/16" hex key (x1)