

150S-300WOG GATE VALVES

FIGURE#103 Screwed-Ends

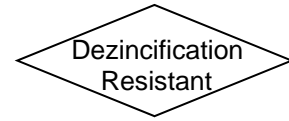
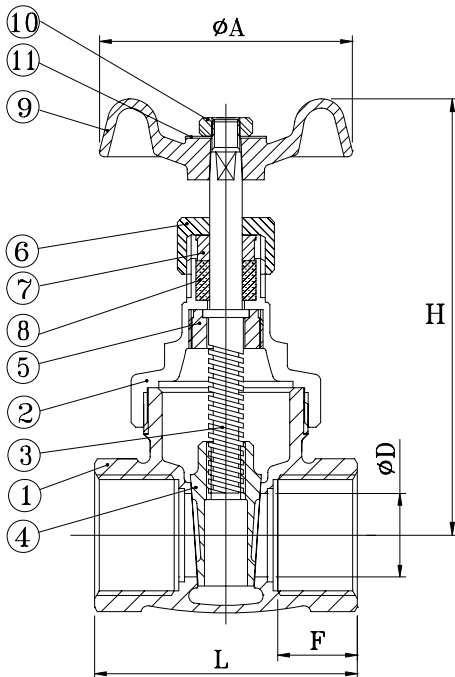

MATERIAL LIST

NO.	NOMENCLATUR	MATERIALS	LEAD FREE
1.	BODY	ASTM B62 C83600	ASTM C87850 or C89833
2.	BONNET	AS 352 DZR BRASS	ASTM C69300
3.	STEM	AS 352 DZR BRASS	ASTM C69300
4.	DISC	ASTM B62 C83600	ASTM C87850 or C89833
5.	LOCK NUT	AS 352 DZR BRASS	ASTM C69300
6.	PACKING NUT	AS 352 DZR BRASS	ASTM C69300
7.	GLAND	AS 352 DZR BRASS	ASTM C69300
8.	GLAND PACKING	TEFLON	TEFLON
9.	HANDWHEEL	CAST IRON	CAST IRON
10.	WHEEL NUT	STEEL	STEEL
11.	NZME PLATE	ALUMINUM	ALUMINUM

Size		L	D	H	A	F	THICKNESS
½"	in	2.01	0.5	3.35	2.13	0.45	0.075
	mm	51	12.7	85	54	11.4	1.9
¾"	in	2.22	0.75	3.58	2.4	0.5	0.083
	mm	56.5	19	91	61	12.7	2.1
1"	in	2.56	0.99	4.29	2.76	0.57	0.095
	mm	65	25	109	70	14.5	2.4
1¼"	in	2.87	1.25	4.92	3.03	0.66	0.102
	mm	73	31.7	125	77	16.8	2.6
1½"	in	3.03	1.5	5.39	3.27	0.66	0.110
	mm	77	38.1	137	83	16.8	2.8
2"	in	3.43	1.97	6.38	3.94	0.83	0.126
	mm	87	50	162	100	21.1	3.2
2½"	in	4.02	0.25	8.31	4.41	0.91	0.146
	mm	102	63.5	211	112	23.2	3.7
3"	in	4.25	3	9.1	5.2	1.04	0.162
	mm	108	76.2	231	132	26.3	4.1
4"	in	4.73	3.94	10.79	5.2	1.27	0.182
	mm	120	100	274	132	32.3	4.6

DESIGN FEATURES:

1. AS1628 AUSTRALIAN STANDARD

2. Pressure

Shell Test Pressure 3750 KPa

Seat Test Pressure 2850 KPa

3. Allowable Pressure

Allowable operating pressure 2500 KPa

Allowable maximum operating pressure 2850 KPa

Allowable test pressure 3750 KPa

4. FEMALE THREADED ENDS COMPLYING WITH BS21[ISO 7]