

Cim 3739B

BALANCING VALVE VARIABLE ORIFICE - PN16 - CAST IRON - DRILLED FLANGE PN 16



This article was made in compliance with the quality management requirements of ISO 9001 standard. All articles are tested according to the EN 12266-1 standard.

It can be used in a wide variety of sectors: heating, air conditioning, water, sanitary systems and generally with any non corrosive liquid.

It is guaranteed for 5 years.

It is made of EN-JL 1040 cast iron.

Nominal Pressure: PN16

Operating temperature: -10 ÷ 120°C

PRESSURE TEMPERATURE RATINGS

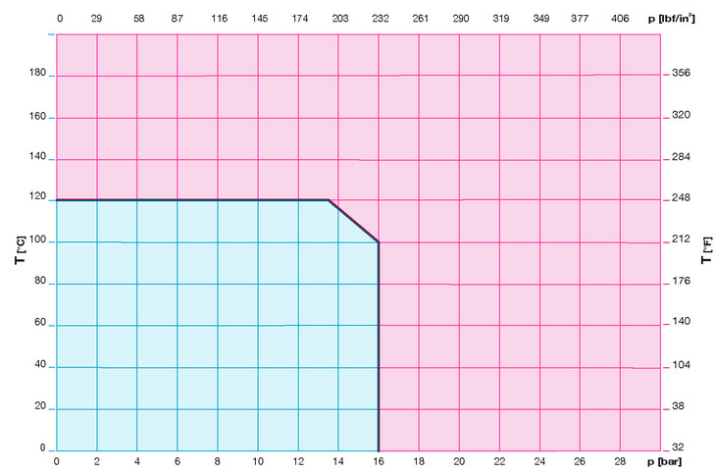

Notes:

1 bar = 14,5 psi

1 bar = 14,5 lbf/in²

°C = 5/9 x (°F-32)

°F = 32 + (9/5 x °C)

TECHNICAL DRAWING

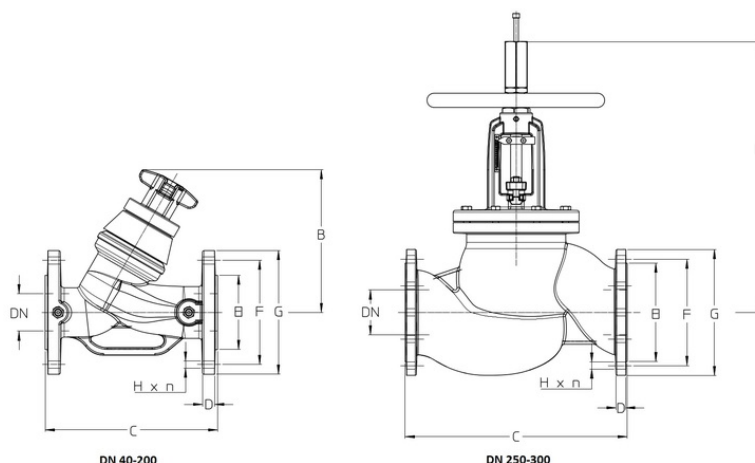

| DN | 40 | 50 | 65 | 80 | 100 | 125 | 150 | 200 | 250 | 300 |
|-------------|------------|-------------|-------------|-------------|-------------|-------------|-------------|------------|------------|------------|
| Kgs. | 8,2 | 11,6 | 15,6 | 19,8 | 34,8 | 52,4 | 78,6 | 173 | 254 | 350 |
| B | 178 | 190 | 215 | 225 | 334,5 | 369 | 403 | 732 | 739,5 | 848,5 |
| C | 200 | 230 | 290 | 310 | 350 | 400 | 480 | 600 | 730 | 850 |
| D | 14 | 16 | 17 | 19 | 21 | 22 | 21 | 26 | 29 | 28 |
| E | 84 | 99 | 118 | 132 | 156 | 178 | 211 | 266 | 320 | 370 |
| F | 110 | 125 | 145 | 160 | 180 | 210 | 240 | 295 | 355 | 410 |
| G | 150 | 165 | 185 | 200 | 220 | 250 | 285 | 340 | 405 | 460 |
| H | 19 | 19 | 19 | 19 | 19 | 19 | 23 | 23 | 28 | 28 |
| n | 4 | 4 | 4 | 8 | 8 | 8 | 8 | 12 | 12 | 12 |

Flanging:
ISO 7005-2

TECHNICAL CHARACTERISTICS

KV - KVS

| DN | 40 | 50 | 65 | 80 | 100 | 125 | 150 | 200 | 250 | 300 |
|----------|-------|-------|-------|--------|--------|--------|--------|--------|--------|---------|
| KV - KVS | 29,32 | 47,63 | 72,09 | 103,68 | 186,01 | 307,78 | 355,11 | 790,63 | 955,29 | 1353,60 |

KV = Flow rate in m³/h at a pressure drop of 1 bar

KVS = Water flow rate that causes a pressure drop of 1 bar measured on the pressure connections

REACH Regulation

According to article 33 of REACH Regulation, we inform you that the components made of bronze and brass alloys that are parts of the articles we supply, contain the lead (as alloy component) in a higher quantity of the limit of 0,1% in weight. Lead has been inserted in the list of SVHC substances nominated for the authorisation process, in the updating published by the European Chemical Agency ECHA on 27th June 2018. Lead has been introduced with the following information:

- Substance: Lead
- CAS: 7439-92-1
- EC: 231-100-4
- List: SVHC
- Data of Inclusion: 27th June 2018

Since lead is an element of the alloy, no exposure is expected and consequently, no further information is requested for the safe use of this product.

The list is available at the following link: <https://echa.europa.eu/it/candidate-list-table> and since it is a continuously updated list, we declare the constant monitoring about insertion of new substances and the prompt on time information to our customers in case such substances should be contained in the products we supply.

Make sure product materials and features are suitable for system scope and conform to the local regulations in force

OUR CERTIFICATIONS

